



SPECIFICATIONS

规格书

Customer Name: _____

客户名称:

Customer P/N: _____

客户品号:

Factory P/N: DZ-1608WHBP-CCM-K002

公司品号:

Sending Date: _____

送样日期:

Client approval 客户审核			Dezhen approval 德真光源审核		
Approval 核准	Audit 确认	Confirmation 制作	Approval 核准	Audit 确认	Confirmation 制作
<input type="checkbox"/> Qualified 接受		<input type="checkbox"/> Disqualified 不接受		DATE:	

地址: 惠州市仲恺高新区沥林镇中集智谷产业园 8 栋

Adr: Building 8, Zhongjizhi Valley Industrial Park, Lilin Town, Zhongkai High-tech Zone, Huizhou City

电话/Tel: 0752-8800515 传真/Fax: 0752-8800515

网址/Web: www.dz-led.com

Features 特点

- Size (mm): 1.6*0.8*0.7 (尺寸为 1.6*0.8*0.7)
- Extremely wide viewing angle (发光角度宽)
- ROHS compliant (符合 ROHS 认证)
- Color :White (颜色:白光)
- Package:4000pcs/reel (包装每卷 4000 颗)

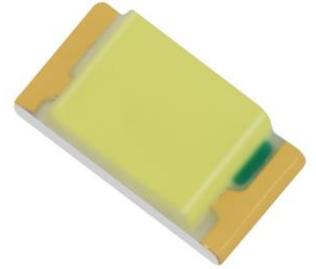

Applications 应用

Backlight for LCD, switch and Symbol, display、Instrument backlight
LCD 背光、转换器，开关和标志，显示、仪表盘等领域

Package Dimensions (封装尺寸)

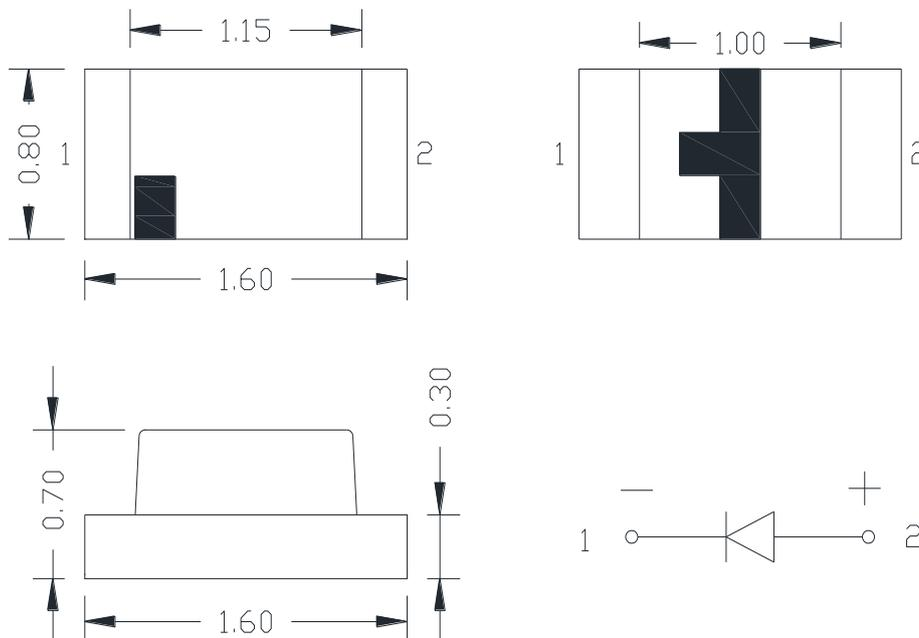

Recommended Soldering Pattern (建议焊盘尺寸图)

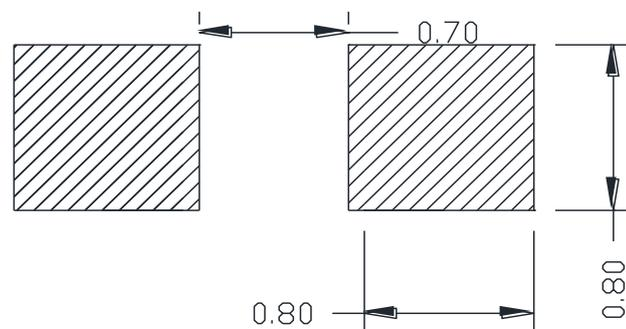

Notes:

All dimension units are millimeters. (所有标注尺寸单位为毫米);

Tolerance is ± 0.1 mm unless otherwise noted. (除特别注明外，所有尺寸均公差 ± 0.1 mm)。

Absolute Maximum Ratings 最大限定参数(Ta=25℃)

Parameter 项目名称	Symbol 符号	Value 规格	Unit 单位
Power dissipation 消耗功率	Pd	100	mW
Forward current 正向电流	If	30	mA
Reverse voltage 反向电压	Vr	10	V
Operating temperature range 工作温度范围	Top	-35 ~+85	℃
Storage temperature range 储存温度范围	Tstg	-40 ~+85	℃
Pulse Forward Current 正向脉冲电流	Ifp	80	mA

Electro-optical characteristics 主要光电参数(Ta=25℃)

Parameter 项目名称	Test Condition 测试条件	Symbol 项目符号	MIN. 最小值	TYP. 中间值	MAX. 最大值	Unit 单位
Forward voltage 正向电压	If=5mA	VF	2.55	--	3.05	V
Luminous Intensity 光强	If=5mA	IV	300	350	400	mcd
Viewing Angle 角度	If=5mA	2 θ 1/2	--	120	--	Deg
Reverse current 反向电流	Vr=10V	IR	--	--	1	μA
Color Coordinates 色度坐标	If=5mA	X	0.23	--	0.32	--
		Y	0.23	--	0.32	--

NOTES 注释:

Tolerance: IV±5%, λd±2nm, Vf±0.05V, X, Y ±0.01

公差:光强 ±5%,主波长±2nm, 正向电压±0.05V, 色坐标 X, Y ±0.01

IFP Conditions: Pulse Width ≦ 10msec and Duty ≦ 1/10.

峰值电流条件: 脉冲范围 ≦ 10 毫秒, 占空比 ≦ 1/10.

Typical optical characteristics curves 典型光学特性曲线

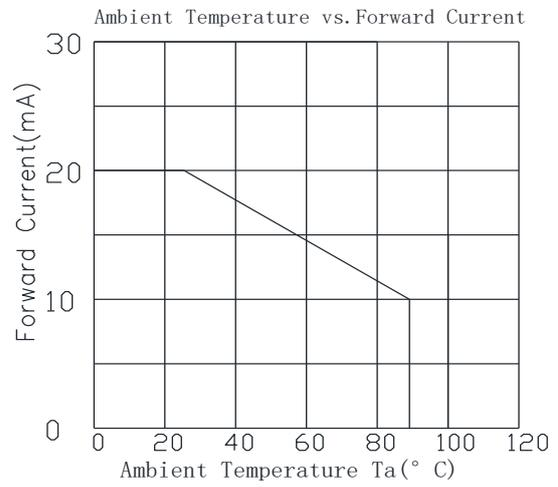
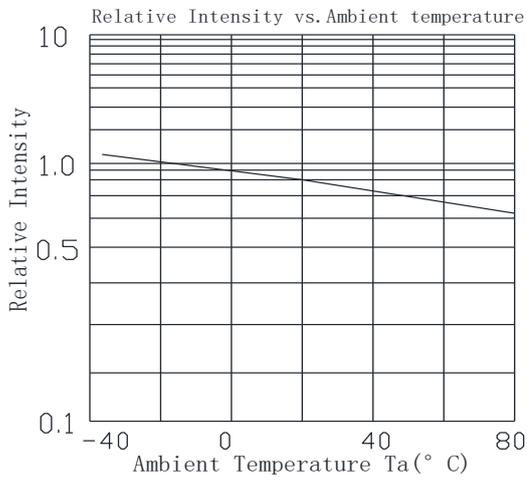
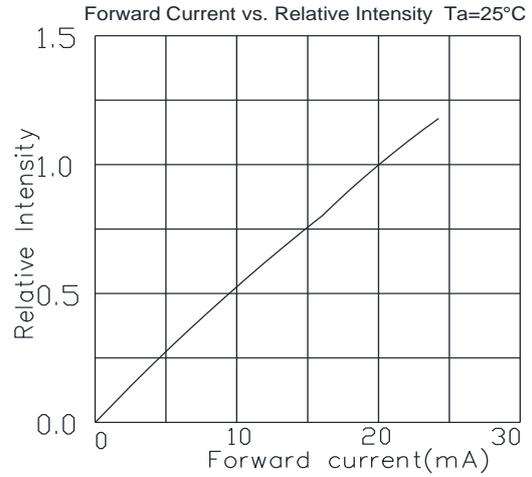
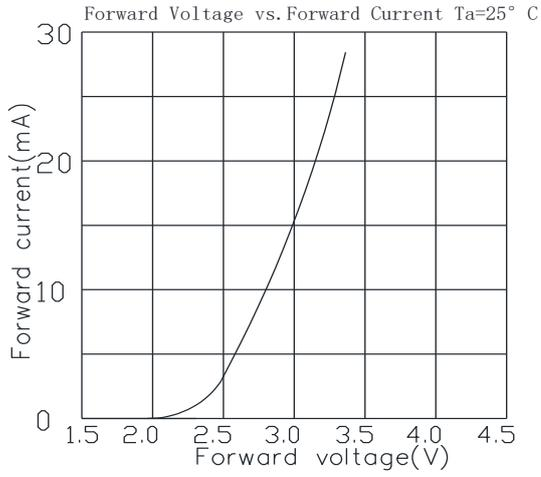

Curves of beam angle and relative brightness

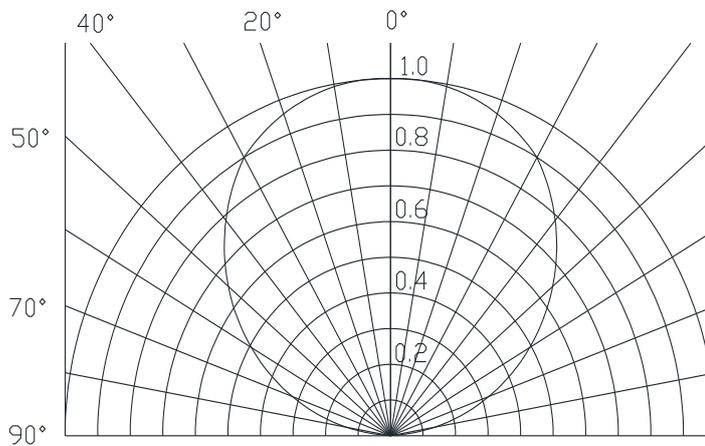



Color bin limit 色区范围

色区	X	Y	色区	X	Y	色区	X	Y	色区	X	Y
A01	0.2084	0.2024	A02	0.2338	0.2332	A03	0.2391	0.2439	A04	0.2445	0.2546
	0.2338	0.2332		0.2391	0.2439		0.2445	0.2546			
	0.2407	0.2093		0.2461	0.24		0.2515	0.2508			
	0.2354	0.2186		0.2407	0.2093		0.2461	0.24			
A05	0.2499	0.2654	A06	0.2544	0.2743	A07	0.2588	0.2833	A08	0.2633	0.2920
	0.2544	0.2743		0.2588	0.2833		0.2633	0.2920			
	0.2613	0.2705		0.2658	0.2794		0.2703	0.2884			
	0.2569	0.2615		0.2613	0.2705		0.2658	0.2794			
B01	0.2354	0.2186	B02	0.2407	0.2093	B03	0.2461	0.24	B04	0.2515	0.2508
	0.2407	0.2093		0.2461	0.24		0.2515	0.2508			
	0.2477	0.2055		0.2531	0.2362		0.2585	0.2469			
	0.2423	0.2147		0.2477	0.2055		0.2531	0.2362			
B05	0.2569	0.2615	B06	0.2613	0.2705	B07	0.2658	0.2794	B08	0.2703	0.2884
	0.2613	0.2705		0.2658	0.2794		0.2703	0.2884			
	0.2683	0.2666		0.2728	0.2756		0.2773	0.2845			
	0.2638	0.2577		0.2683	0.2666		0.2728	0.2756			

CIE Chromaticity Diagram 色区图

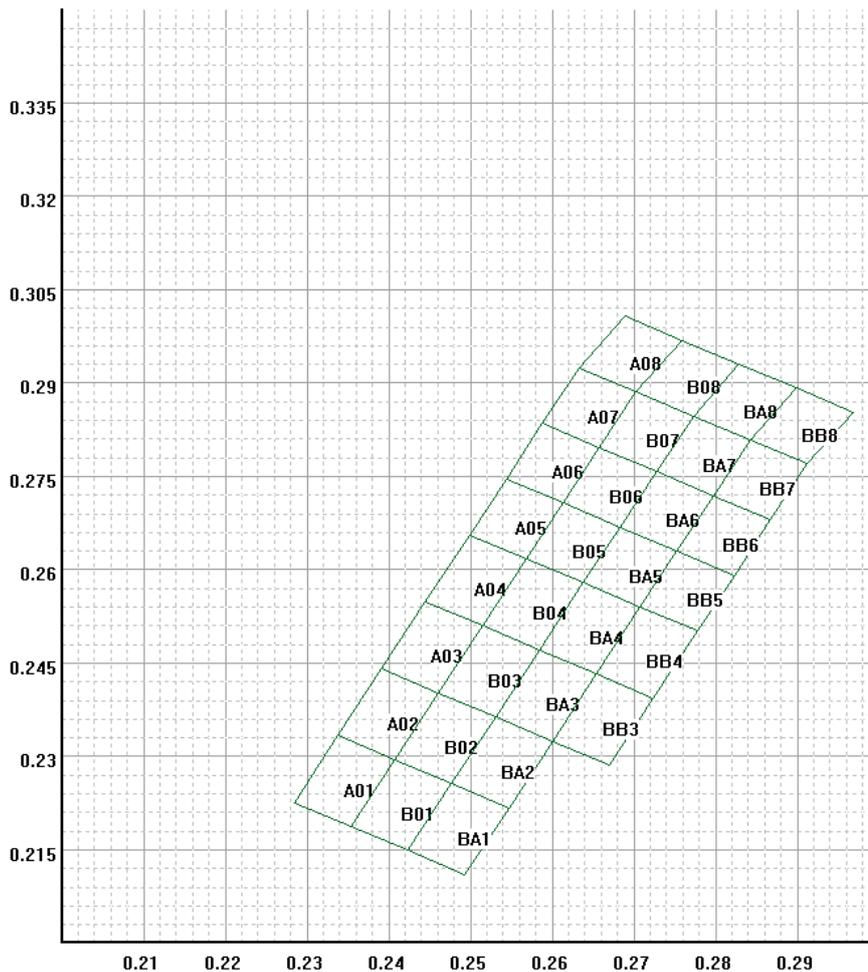



Reliability Test Items And Conditions 信赖性测试项目及条件

Test Items 项目	Ref.Standard 参考标准	Test Condition 测试条件	Time 时间	Quantity 数量
Reflow 回流焊	JESD22-B106	Temp:260°Cmax T=10 sec	3 times.	20Pcs.
Thermal Shock 冷热冲击	JESD22-A104	120°C±5°C 15 min. ↑↓10sec -40°C±5°C 15 min.	100 Cycles	20Pcs.
High Temperature Storage 高温保存	JESD22-A103	Temp:100°C±5°C	1000Hrs.	20Pcs.
Low Temperature Storage 低温保存	JESD22-A119	Temp:-40°C±5°C	1000Hrs.	20Pcs.
Life Test 常温通电	JESD22-A108	Ta=25°C±5°C IF=20mA	1000Hrs.	20Pcs.
High Temperature High Humidity 高温高湿保存	JESD22-A101	85°C±5°C/ 85%RH	1000Hrs.	20Pcs.

Criteria For Judging Damage 失效判定标准

Test Items 项目	Symbol 符号	Test Condition 测试条件	Criteria For Judgement 判定标准	
			Min. 最小	Max. 最大
Forward Voltage 正向电压	VF	IF=20mA	--	U.S.L*)x1.1
Reverse Current 反向电流	IR	VR = 5V	--	U.S.L*)x2.0
Luminous Intensity 光强	IV	IF=20mA	L.S.L*)x0.7	--

U.S.L: Upper standard level 规格上限 L.S.L: Lower standard level 规格下限

*The technical information shown in the data sheets are limited to the typical characteristics and circuit examples of the referenced products. It does not constitute the warranting of industrial property nor the granting of any license. 数据工作表中所示的技术信息仅限于典型特征和电路实例引用的产品.它既不构成工业特性的保证,也不构成任何许可的授权

Packaging 包装

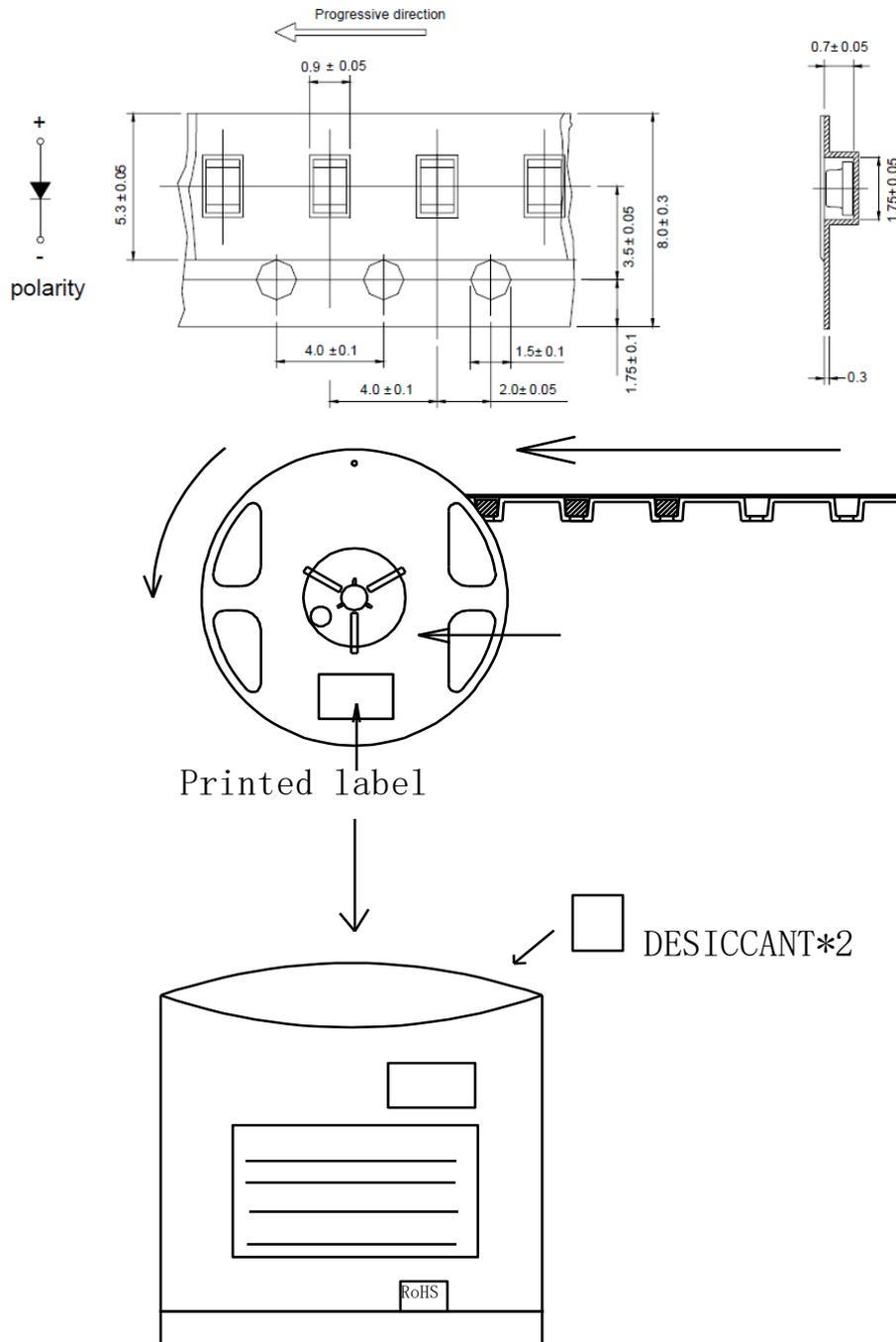

Notes 备注:

1. Empty component pockets are sealed with top cover tape;
预留载带空位也贴有上封带
2. The maximum number of missing lamps is two;
最多缺失的 LED 不能超过两颗
3. The cathode is oriented towards the tape sprocket hole in accordance with ANSI/EIA RS-481 specifications.
根据 ANSI/EIA RS-481 的规格,产品的负极指向卷带的导孔.
4. 4,000 pcs / Reel.
4,000 颗/卷

Requirements for application and reflow soldering 应用及回流焊要求:

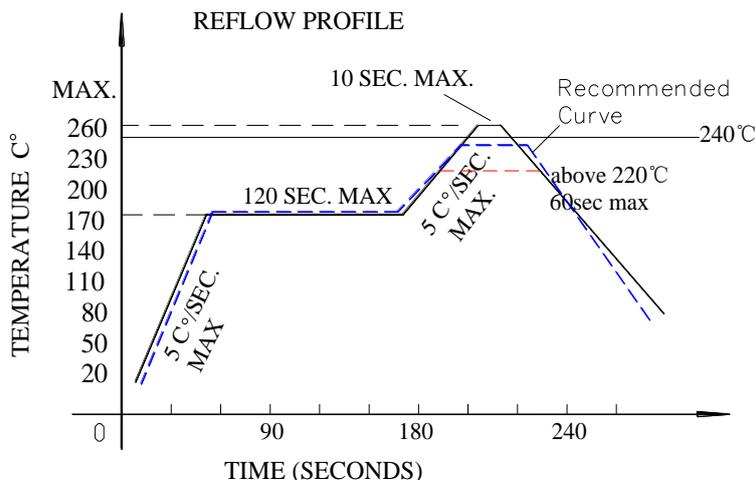

Reflow soldering curve 回流焊曲线图

(Product is highest resistant to 260°C reflow but suggested the highest temperature of 240°C within)

(产品最高可耐260°C回流焊, 但建议最高温度设为240°C)

■ **Notes for reflow soldering 回流焊注意事项:**

1. No more than twice for reflow soldering.
注意回流焊不可超过两次。
2. When soldering, do not put stress on the LEDs during heating
在焊接时, 不能在材料受热时用力压胶体表面。

■ **Soldering iron 烙铁焊接**

1. During the soldering, the electronic soldering iron must be kept under the temperature of 300°C and the soldering time must not be beyond 3 seconds. No touch between the electronic soldering iron and colloid.
手工焊接时, 要保持电烙铁温度在 300 摄氏度以下, 并且焊接时间小于 3 秒, 电烙铁不可接触胶体。
2. Handwork soldering is only allowed once.
手工焊接只可进行一次。
3. Avoid using sharp objects to compress products Colloidal Part directly.
避免使用尖锐的物体直接接触产品胶体部分。

Notes 备注

1. Static and Peak surge voltage can destroy LED, Avoiding Instantaneous voltage when turn on or turn off the lights.
静电或峰值浪涌电压会损坏 LED, 避免在开灯、关灯时产生瞬时电压。
2. Please put on the antistatic hand loop during the use. The worktable should be with antistatic finish. The equipments must be contacted with ground.
使用时请佩带防静电手环, 工作台做好防静电处理, 机台设备等保证接地。
3. Use anti-static packaging for transport and storage.
运输和储存需用防静电袋包装。

Storage 储存

1. Storage condition before opening the package: 5°C~30°C, the largest percentage relative humidity is 60%RH and the storage period is one year.

未拆封前在5°C~30°C，最大相对湿度60%RH的环境以下，储存时间为1年。

2. The SMD LEDs should be used with 48 hours in condition of temperature no more than 30°C and humidity no more than 60%RH. The rest products should be pressurized in vacuum condition with desiccants. Stored for more than 7 days, next time also must be dehumidification, the dehumidification conditions is 60±5°C with 24hours.

开封后，LED 在≤30°C,≤60%RH 相对湿度的条件下，必须在48 小时内用完，未用完的产品重新真空密封，并放置在一个密封容器中，同时必须使用干燥剂。存储超过7 天，下次使用时同样需要进行除湿操作，除湿条件为60±5°C 24 小时。

Cleaning 清洗

1. Recommended to be wiped with isopropyl alcohol or pure alcohol, wiping time should not be more than one minute. LED must be placed at room temperature for fifteen minutes before using.

建议使用异丙醇、纯酒精擦拭，不要超过1分钟，在室温下放置15 分钟后再使用。

2. LED can not be in contact with acetone, isoamyl acetate, sulfide, acid, alkali. These matter can destroy LED.

LED 不能接触丙酮、天那水、硫化物、酸、碱类, 这些物质会损伤 LED。